

RETAINER 50 Kg FOR FLOOR AE/V-R2450F

Description

They are used to keep fire doors open and automatically release them in the event of a fire. It consists of two parts, the electromagnet itself and the plywood. The electromagnet has an unlock button and can be mounted on the floor.



Dimensions

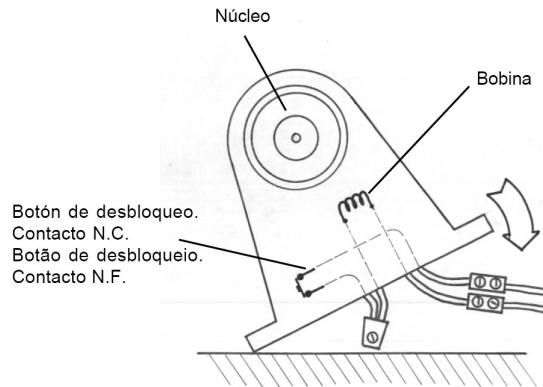
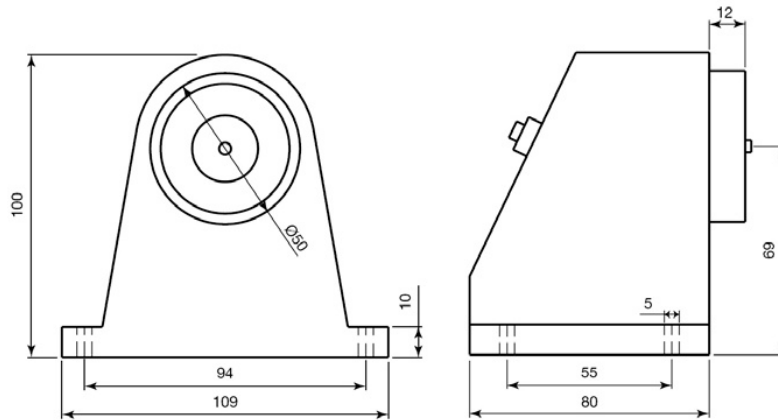

TECHNICAL CHARACTERISTICS

Material:	Aluminum
Operating temperature:	-10°C + 55°C
Protection degree:	IP40
Power:	24Vdc
Consumption:	45mA
Clamping force:	50Kg / 490N